

Electric Powered Forklift 1.5 - 2.0 ton

BT cargo E4

C3E150

C3E160-180

C3E160L-180L

C3E200



Electric Powered Forklift 1.5 ton

Truck specifications					C3E150	
Identification	1.1	Manufacturer			BT	
	1.2	Model			C3E150	
	1.3	Drive			Electric	
	1.4	Operator type			Rider seated	
	1.5	Load capacity/rated load	Q	kg	1500	
	1.6	Load centre	c	mm	500	
	1.8	Load distance, centre of drive axle to fork	x	mm	351,5 ¹⁾	
	1.9	Wheelbase	y	mm	1262	
	Weight	2.1	Service weight		kg	3044 ²⁾
2.2		Axle load, with load, front/rear		kg	3947/597	
2.3		Axle load, without load, front/rear		kg	1434/1610	
Tyres	3.1	Tyres: Cushion (C), Pneumatic (PN), Superelastic (SE)			C/SE	
	3.2	Tyre size, front			432x152 / 18x7-8	
	3.3	Tyre size, rear			381x127 / 140/55-9	
	3.5	Wheels, number front/rear (x=driven wheels)			2x/2	
	3.6	Track width, front	b ₁₀	mm	889/901 ³⁾	
	3.7	Track width, rear	b ₁₁	mm	192/185 ³⁾	
	Dimensions	4.1	Tilt of mast/fork carriage forward/backward	α/β	deg	5/7 ⁴⁾
4.2		Height, mast lowered	h ₁	mm	2160	
4.3		Free lift	h ₂	mm	80	
4.4		Lift	h ₃	mm	3170	
		Lift height	h ₂₃	mm	3205	
4.5		Height, mast extended	h ₄	mm	3720	
4.7		Height of overhead guard (cab)	h ₆	mm	2050	
4.8		Seat height/stand height	h ₇	mm	937	
4.12		Coupling height	h ₁₀	mm	500	
4.19		Overall length	l ₁	mm	2803	
4.20		Length to face of forks	l ₂	mm	1803	
4.21		Overall width	b ₁	mm	1050	
4.22		Fork dimensions	s/e/l	mm	35/100/1000	
4.23		Fork carriage DIN 15 173, class/type A, B			II A	
4.24		Fork-carriage width	b ₃	mm	920	
4.31		Ground clearance, with load, below mast	m ₁	mm	100	
4.32		Ground clearance, centre of wheelbase	m ₂	mm	90	
4.33		Aisle width for pallets 1000 x 1200 crossways	A _{st}	mm	3130	
4.34	Aisle width for pallets 800 x 1200 lengthways	A _{st}	mm	3254		
4.35	Turning radius	W _a	mm	1451,5		
4.36	Internal turning radius	b ₁₃	mm	0		
Performance data	5.1	Travel speed, with/without load		km/h	16,0/16,0	
	5.2	Lift speed, with/without load		m/s	0,40/0,60	
	5.3	Lowering speed, with/without load		m/s	0,55/0,50	
	5.5	Drawbar pull, with/without load		N	5200/5400	
	5.6	Max. drawbar pull, with/without load		N	14450/15000	
	5.7	Gradeability, with/without load		%	14,0/16,5	
	5.8	Max. gradeability, with/without load		%	28/32	
	5.10	Service brake			Electric/ Hydraulic	
	Electric motor	6.1	Drive motor rating S2 60 min		kW	6x2
		6.2	Lift motor rating S3 15%		kW	15,8
6.3		Battery acc. to DIN 43 531/35/36 A, B, C, no			43 531 A	
6.4		Battery voltage, nominal capacity K ₅		V/Ah	48/420-500	
6.5		Battery weight		kg	708	
Others	8.1	Type of drive control			Inverter MOSFET	
	8.2	Operating pressure for attachments		bar	140	
	8.3	Oil volume for attachments		l/min		
	8.4	Sound level at the driver's ear according to EN 12 053		dB(A)		

1) +34 mm with integrated sideshift

2) includes battery weight

3) C/ SE

4) 5° backward with front windshield

Performance data and dimensions are nominal and subject to tolerances.

Specifications are subject to change without notice.

Please obtain the latest specifications before contracting products.

Most dimensions and rated capacities

Model			Duplex NFL								Duplex FFL					Triplex FFL									
C3E150	Lift height	h_{23}	3005	3205	3505	3705	4005	4205	4505	4705	5005	3005	3205	3505	3705	4005	4005	4305	4505	4705	5005	5605	6505	7005	7505
	Lift	h_3	2970	3170	3470	3670	3970	4170	4470	4670	4970	2970	3170	3470	3670	3970	3970	4270	4470	4670	4970	5570	6470	6970	7470
	Height, mast lowered	h_1	2060	2160	2310	2410	2560	2660	2810	2910	3110	2060	2160	2410	2410	2560	1890	1990	2060	2160	2260	2460	2810	3010	3210
	Height, mast extended	h_4	3520	3720	4020	4220	4520	4720	5020	5220	5555	3550	3750	4050	4250	4550	4550	4850	5050	5250	5550	6150	7050	7550	8050
	Free lift	h_2	80	80	80	80	80	80	80	80	80	1480	1580	1730	1830	1980	1310	1410	1480	1580	1680	1880	2230	2430	2630

Superelastic / Cushion tyre			Duplex NFL								Duplex FFL					Triplex FFL								
C3E150	Tilt range, forward	deg	5	5	5	5	5	5	5	5	5	5	5	5	5	5	5	5	5	5	5	5	5	5
	Tilt range, backward	deg	7	7	7	7	7	7	7	7	7	7	7	7	7	7	7	7	7	7	7	7	7	7
	Load capacity at 500 mm LC	kg	1500	1500	1500	1500	1500	1450	1450	1400	1400	1500	1500	1500	1500	1500	1450	1400	1400	1350	1300	1200	950	700

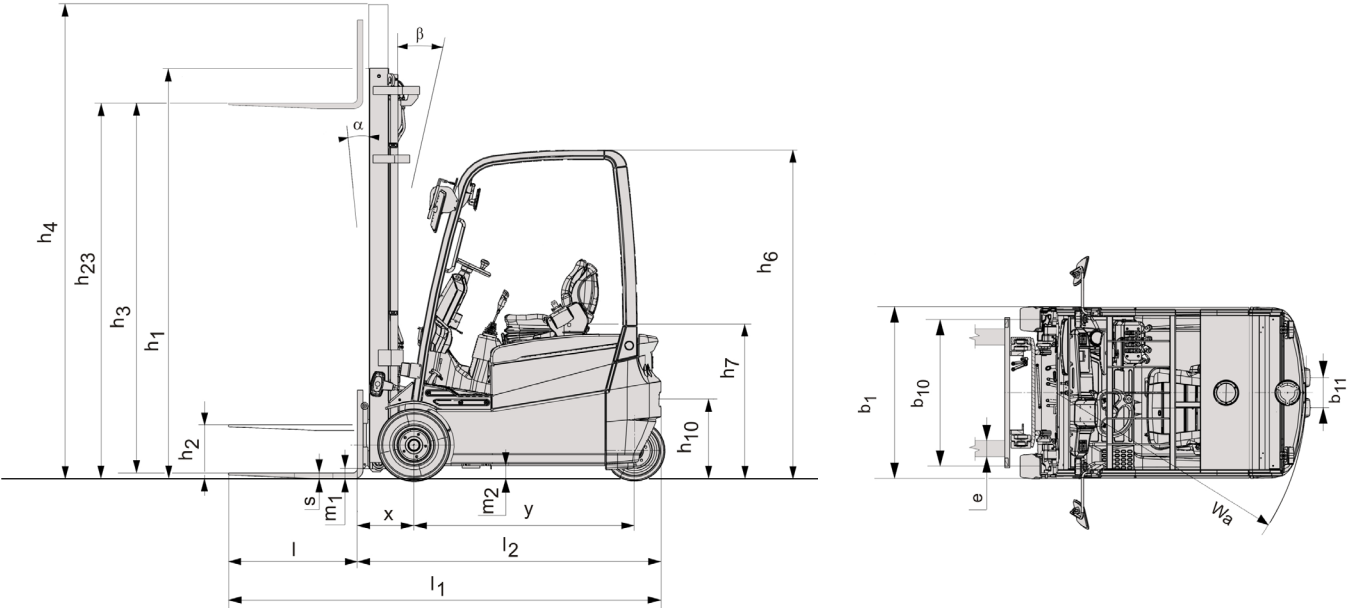

Electric Powered Forklift 1.6 - 1.8 ton

Truck specifications						C3E160	C3E180		
Identification	1.1	Manufacturer				BT	BT		
	1.2	Model				C3E160	C3E180		
	1.3	Drive				Electric	Electric		
	1.4	Operator type				Rider seated	Rider seated		
	1.5	Load capacity/rated load	Q	kg		1600	1800		
	1.6	Load centre	c	mm		500	500		
	1.8	Load distance, centre of drive axle to fork	x	mm		351,5 ¹⁾	365,5 ¹⁾		
	1.9	Wheelbase	y	mm		1370	1370		
	Weight	2.1	Service weight		kg		3067 ²⁾	3299 ²⁾	
2.2		Axle load, with load, front/rear		kg		4110/557	4540/559		
2.3		Axle load, without load, front/rear		kg		1515/1552	1603/1696		
Tyres	3.1	Tyres: Cushion (C), Pneumatic (PN), Superelastic (SE)				C/SE	C/SE		
	3.2	Tyre size, front				432x152 / 18x7-8	457x178 / 200/50-10		
	3.3	Tyre size, rear				381x127 / 140/55-9	381x127 / 140/55-9		
	3.5	Wheels, number front/rear (x=driven wheels)				2x/2	2x/2		
	3.6	Track width, front	b ₁₀	mm		889/901 ³⁾	879/916 ³⁾		
	3.7	Track width, rear	b ₁₁	mm		192/185 ³⁾	192/185 ³⁾		
	Dimensions	4.1	Tilt of mast/fork carriage forward/backward			α/β	deg	5/7 ⁴⁾	5/7 ⁴⁾
4.2		Height, mast lowered			h ₁	mm	2160	2160	
4.3		Free lift			h ₂	mm	80	80	
4.4		Lift			h ₃	mm	3170	3170	
		Lift height			h ₂₃	mm	3205	3205	
4.5		Height, mast extended			h ₄	mm	3720	3720	
4.7		Height of overhead guard (cab)			h ₆	mm	2050	2050	
4.8		Seat height/stand height			h ₇	mm	937	937	
4.12		Coupling height			h ₁₀	mm	500	500	
4.19		Overall length			l ₁	mm	2886	2925	
4.20		Length to face of forks			l ₂	mm	1886	1925	
4.21		Overall width			b ₁ , b ₂	mm	1050	1057/1109	
4.22		Fork dimensions			s/e/l	mm	35/100/1000	35/120/1000	
4.23		Fork carriage DIN 15 173, class/type A, B					II A	II A	
4.24		Fork-carriage width			b ₃	mm	920	920	
4.31		Ground clearance, with load, below mast			m ₁	mm	100	100	
4.32		Ground clearance, centre of wheelbase			m ₂	mm	90	90	
4.33		Aisle width for pallets 1000 x 1200 crossways			A _{st}	mm	3213	3251	
4.34		Aisle width for pallets 800 x 1200 lengthways			A _{st}	mm	3336	3375	
4.35	Turning radius			W _a	mm	1534,5	1559,5		
4.36	Internal turning radius			b ₁₃	mm	0	0		
Performance data	5.1	Travel speed, with/without load				km/h	16,0/16,0	16,0/16,0	
	5.2	Lift speed, with/without load				m/s	0,40/0,60	0,40/0,60	
	5.3	Lowering speed, with/without load				m/s	0,55/0,50	0,55/0,50	
	5.5	Drawbar pull, with/without load				N	5200/5400	5200/5400	
	5.6	Max. drawbar pull, with/without load				N	14450/15000	14450/15000	
	5.7	Gradeability, with/without load				%	13,5/16,0	13,0/15,5	
	5.8	Max. gradeability, with/without load				%	27/31	25/30	
	5.10	Service brake					Electric/ Hydraulic	Electric/ Hydraulic	
	Electric motor	6.1	Drive motor rating S2 60 min			kW		6x2	6x2
		6.2	Lift motor rating S3 15%			kW		15,8	15,8
6.3		Battery acc. to DIN 43 531/35/36 A, B, C, no					43 531 A	43 531 A	
6.4		Battery voltage, nominal capacity K ₅			V/Ah		48/525-625	48/525-625	
6.5		Battery weight			kg		856	856	
Others	8.1	Type of drive control					Inverter MOSFET	Inverter MOSFET	
	8.2	Operating pressure for attachments			bar		140	140	
	8.3	Oil volume for attachments			l/min				
	8.4	Sound level at the driver's ear according to EN 12 053			dB(A)				

1) +34 mm with integrated sideshift

2) includes battery weight

3) C/ SE

4) 5° backward with front windshield

Performance data and dimensions are nominal and subject to tolerances. Specifications are subject to change without notice.

Please obtain the latest specifications before contracting products.

Most dimensions and rated capacities

Model			Duplex NFL								Duplex FFL					Triplex FFL									
C3E160/180	Lift height	h_{23}	3005	3205	3505	3705	4005	4205	4505	4705	5005	3005	3205	3505	3705	4005	4005	4305	4505	4705	5005	5605	6505	7005	7505
	Lift	h_3	2970	3170	3470	3670	3970	4170	4470	4670	4970	2970	3170	3470	3670	3970	3970	4270	4470	4670	4970	5570	6470	6970	7470
	Height, mast lowered	h_1	2060	2160	2310	2410	2560	2660	2810	2910	3110	2060	2160	2410	2410	2560	1890	1990	2060	2160	2260	2460	2810	3010	3210
	Height, mast extended	h_4	3520	3720	4020	4220	4520	4720	5020	5220	5555	3550	3750	4050	4250	4550	4550	4850	5050	5250	5550	6150	7050	7550	8050
	Free lift	h_2	80	80	80	80	80	80	80	80	80	1480	1580	1730	1830	1980	1310	1410	1480	1580	1680	1880	2230	2430	2630

Superelastic / Cushion tyre			Duplex NFL								Duplex FFL					Triplex FFL								
C3E160	Tilt range, forward	deg	5	5	5	5	5	5	5	5	5	5	5	5	5	5	5	5	5	5	5	5	5	5
	Tilt range, backward	deg	7	7	7	7	7	7	7	7	7	7	7	7	7	7	7	7	7	7	7	7	7	7
	Load capacity at 500 mm LC	kg	1600	1600	1600	1600	1600	1550	1500	1450	1450	1600	1600	1600	1600	1600	1500	1500	1500	1450	1450	1300	1050	750
C3E180	Tilt range, forward	deg	5	5	5	5	5	5	5	5	5	5	5	5	5	5	5	5	5	5	5	5	5	5
	Tilt range, backward	deg	7	7	7	7	7	7	7	7	7	7	7	7	7	7	7	7	7	7	7	7	7	7
	Load capacity at 500 mm LC	kg	1800	1800	1800	1800	1800	1750	1700	1650	1550	1800	1800	1800	1800	1750	1700	1650	1650	1550	1500	1350	1050	750

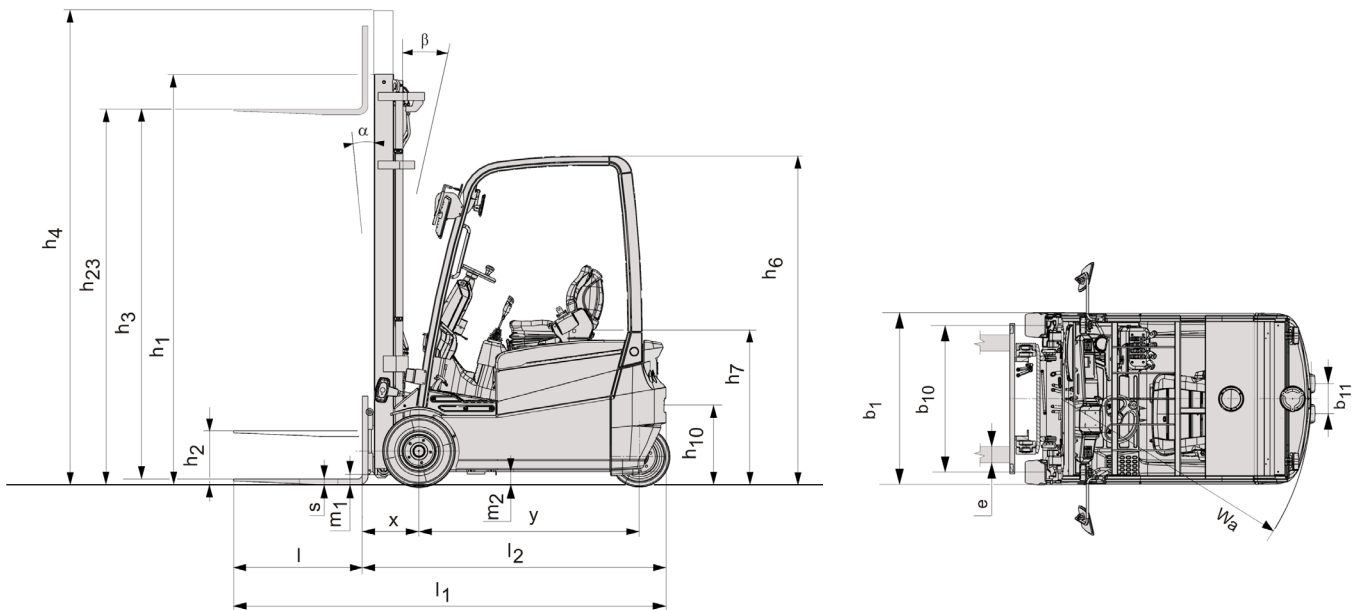

Electric Powered Forklift 1.6 - 2.0 ton

Truck specifications					C3E160L	C3E180L	C3E200
Identification	1.1	Manufacturer			BT	BT	BT
	1.2	Model			C3E160L	C3E180L	C3E200
	1.3	Drive			Electric	Electric	Electric
	1.4	Operator type			Rider seated	Rider seated	Rider seated
	1.5	Load capacity/rated load	Q	kg	1600	1800	2000
	1.6	Load centre	c	mm	500	500	500
	1.8	Load distance, centre of drive axle to fork	x	mm	351,5 ¹⁾	365,5 ¹⁾	365,5 ¹⁾
	1.9	Wheelbase	y	mm	1478	1478	1478
	Weight	2.1	Service weight		kg	3104 ²⁾	3333 ²⁾
2.2		Axle load, with load, front/rear		kg	4118/586	4545/588	4586/627
2.3		Axle load, without load, front/rear		kg	1596/1508	1691/1642	1685/1798
Tyres	3.1	Tyres: Cushion (C), Pneumatic (PN), Superelastic (SE)			C/SE	C/SE	C/SE
	3.2	Tyre size, front			432x152/18x7-8	457x178 / 200/50-10	457x178 / 200/50-10
	3.3	Tyre size, rear			381x127/140/55-9	381x127/140/55-9	381x127/140/55-9
	3.5	Wheels, number front/rear (x=driven wheels)			2x/2	2x/2	2x/2
	3.6	Track width, front	b ₁₀	mm	889/901 ³⁾	879/916 ³⁾	879/916 ³⁾
	3.7	Track width, rear	b ₁₁	mm	192/185 ³⁾	192/185 ³⁾	192/185 ³⁾
	Dimensions	4.1	Tilt of mast/fork carriage forward/backward			α/β	deg
4.2		Height, mast lowered			h ₁	mm	2160
4.3		Free lift			h ₂	mm	80
4.4		Lift			h ₃	mm	3170
		Lift height			h ₂₃	mm	3205
4.5		Height, mast extended			h ₄	mm	3720
4.7		Height of overhead guard (cab)			h ₆	mm	2050
4.8		Seat height/stand height			h ₇	mm	937
4.12		Coupling height			h ₁₀	mm	500
4.19		Overall length			l ₁	mm	2994
4.20		Length to face of forks			l ₂	mm	1994
4.21		Overall width			b ₁	mm	1050
4.22		Fork dimensions			s/e/l	mm	35/100/1000
4.23		Fork carriage DIN 15 173, class/type A, B					II A
4.24		Fork-carriage width			b ₃	mm	920
4.31		Ground clearance, with load, below mast			m ₁	mm	100
4.32		Ground clearance, centre of wheelbase			m ₂	mm	90
4.33		Aisle width for pallets 1000 x 1200 crossways			A _{st}	mm	3321
4.34		Aisle width for pallets 800 x 1200 lengthways			A _{st}	mm	3444
4.35	Turning radius			W _a	mm	1642,5	
4.36	Internal turning radius			b ₁₃	mm	0	
Performance data	5.1	Travel speed, with/without load				km/h	16,0/16,0
	5.2	Lift speed, with/without load				m/s	0,40/0,60
	5.3	Lowering speed, with/without load				m/s	0,55/0,50
	5.5	Drawbar pull, with/without load				N	5200/5400
	5.6	Max. drawbar pull, with/without load				N	14450/15000
	5.7	Gradeability, with/without load				%	13,5/16,0
	5.8	Max. gradeability, with/without load				%	27/31
5.10	Service brake					Electric/ Hydraulic	
Electric motor	6.1	Drive motor rating S2 60 min				kW	6x2
	6.2	Lift motor rating S3 15%				kW	15,8
	6.3	Battery acc. to DIN 43 531/35/36 A, B, C, no					43 531 A
	6.4	Battery voltage, nominal capacity K ₅				V/Ah	48/690-750
	6.5	Battery weight				kg	1013
Others	8.1	Type of drive control					Inverter MOSFET
	8.2	Operating pressure for attachments				bar	140
	8.3	Oil volume for attachments				l/min	
	8.4	Sound level at the driver's ear according to EN 12 053				dB(A)	

1) +34 mm with integrated sideshift

2) includes battery weight

3) C/ SE

4) 5° backward with front windshield

Performance data and dimensions are nominal and subject to tolerances.

Specifications are subject to change without notice.

Please obtain the latest specifications before contracting products.

Most dimensions and rated capacities

Model		Duplex NFL										Duplex FFL					Triplex FFL								
C3E160L/ 180L/200	Lift height	h_{23}	3005	3205	3505	3705	4005	4205	4505	4705	5005	3005	3205	3505	3705	4005	4005	4305	4505	4705	5005	5605	6505	7005	7505
	Lift	h_3	2970	3170	3470	3670	3970	4170	4470	4670	4970	2970	3170	3470	3670	3970	3970	4270	4470	4670	4970	5570	6470	6970	7470
	Height, mast lowered	h_1	2060	2160	2310	2410	2560	2660	2810	2910	3110	2060	2160	2410	2410	2560	1890	1990	2060	2160	2260	2460	2810	3010	3210
	Height, mast extended	h_4	3520	3720	4020	4220	4520	4720	5020	5220	5555	3550	3750	4050	4250	4550	4550	4850	5050	5250	5550	6150	7050	7550	8050
	Free lift	h_2	80	80	80	80	80	80	80	80	80	1480	1580	1730	1830	1980	1310	1410	1480	1580	1680	1880	2230	2430	2630

Superelastic / Cushion tyre		Duplex NFL										Duplex FFL					Triplex FFL								
C3E160L	Tilt range, forward	deg	5	5	5	5	5	5	5	5	5	5	5	5	5	5	5	5	5	5	5	5	5	5	5
	Tilt range, backward	deg	7	7	7	7	7	7	7	7	7	7	7	7	7	7	7	7	7	7	7	7	7	7	7
	Load capacity at 500 mm LC	kg	1600	1600	1600	1600	1600	1550	1500	1450	1450	1600	1600	1600	1600	1600	1500	1500	1500	1450	1450	1300	1050	750	650
C3E180L	Tilt range, forward	deg	5	5	5	5	5	5	5	5	5	5	5	5	5	5	5	5	5	5	5	5	5	5	5
	Tilt range, backward	deg	7	7	7	7	7	7	7	7	7	7	7	7	7	7	7	7	7	7	7	7	7	7	7
	Load capacity at 500 mm LC	kg	1800	1800	1800	1800	1800	1750	1700	1650	1550	1800	1800	1800	1800	1800	1700	1650	1650	1650	1550	1400	1050	800	700
C3E200	Tilt range, forward	deg	5	5	5	5	5	5	5	5	5	5	5	5	5	5	5	5	5	5	5	5	5	5	5
	Tilt range, backward	deg	7	7	7	7	7	7	7	7	7	7	7	7	7	7	7	7	7	7	7	7	7	7	7
	Load capacity at 500 mm LC	kg	2000	2000	2000	2000	2000	1900	1850	1800	1700	2000	2000	2000	2000	2000	1900	1850	1850	1800	1700	1500	1100	750	700

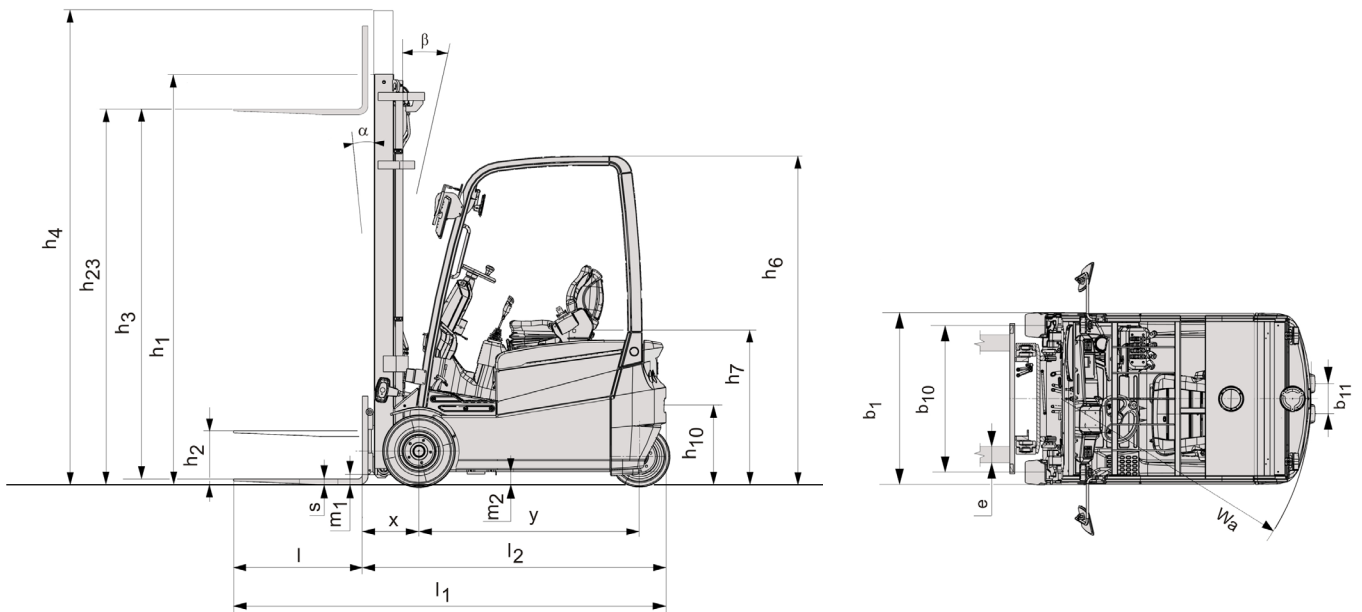

Standard equipment:

- AC technology
- Duplex NFL (height: 3170 mm)
- Long forks (length: 1000 mm)
- Forkbar (length: 920 mm)
- 3 way valve
- Driver side levers
- Tilt steering column
- Multifunction display
- Programmable driving performance
- PIN code access
- Electric parking brake
- Wet disc brakes
- Superelastic tyres

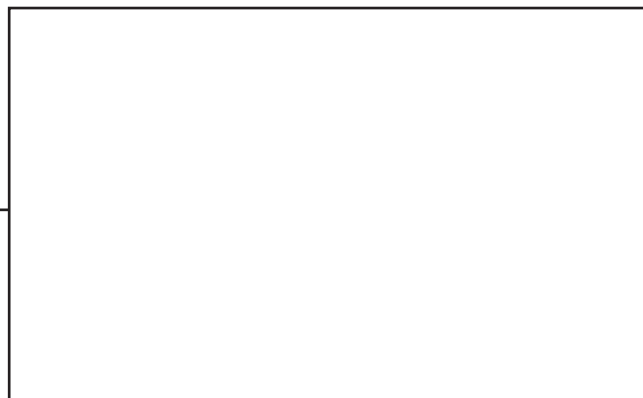

TP-Technical Publications, Sweden — 745570-040, version 2, 1008 — C3E150-200

